

# InfoScript

Technical Operations Manual



**V 2.0.0**

For InfoScript  
Large & Mini Versions

**DURSTMÜLLER GmbH**  
Bergbau- und Drucklufttechnik  
Salzburger Str. 59 | Tel: +43 (0)7245 28250-0  
4650 Lambach | Fax: +43 (0)7245 28250-50  
Austria | e-mail: office@dula.at  
web: www.dula.at



## Important Notice

The InfoScript line of products is the exclusive copyright property of Accutron Instruments INC.

We reserve the right to make changes to the Accutron products and manuals without further notice to improve reliability, function, or design. Accutron Instruments INC does not assume any liability arising out of the application or use of any product described herein, nor does it convey any license under its patent rights, nor the rights of others.

The documentation found within this manual is to provide users of our products with technical information pertaining to the installation, maintenance, and setup of the product.

It is forbidden to use any Accutron documentation for any other purpose which may be detrimental to the interests of Accutron Instruments INC.

PLEASE NOTE: The newest revision of this manual will be available online at [accutroninstruments.com](http://accutroninstruments.com). If you require any assistance in configuring your new Accutron InfoScript, please call our technicians at +1-705-628-0814 or email at [info@accutroninstruments.com](mailto:info@accutroninstruments.com).

## The Manual

Refer to this manual for proper installation, operation, setup, and maintenance of the Accutron InfoScript.

Special attention must be followed to warnings and notices highlighted from the rest of the text to ensure it will stand out.

**Note:** Important information about the product or that part of the manual, helpful hints, and or troubleshooting advice.

- These instructions do not claim to cover all details or variations in equipment, or to provide for every possible contingency that may arise during installation, operation, setup, and maintenance.
- For further information or to resolve issues not covered in the manual, consult the Accutron Technical Service Team.
- The contents of the manual shall not become part of or modify any prior or existing agreement, commitment, or relationship.
- The warranty contained in the contract between parties is the sole warranty of Accutron Instruments INC.

**IMPORTANT:** All specifications are subject to change without notice. Ensure your manual is up to date, the version number can be found on the front page of the manual. If you are unsure, please consult the Accutron Technical Service Team.

---

## Table of Contents

Important Notice .....	i
The Manual .....	ii
Introduction .....	1
Section 1: General Information.....	2
1.1 Safety Guidelines .....	2
1.2 Information About Your Accutron InfoScript.....	2
Section 2: Specifications .....	3
Section 3: Communication and Power Wiring Diagram .....	4
Section 4: Device Overview .....	5
Section 5: Initial Setup .....	6
Section 6: Configuring Screens – The Web Interface.....	6
6.1 Screens.....	7
6.1.1 General Screen Settings .....	7
6.1.2 Line Settings .....	8
6.1.3 Data Source - Text .....	9
6.1.4 Data Source - Modbus Data .....	9
6.1.5 Data Source - Date/Time Display .....	12
6.1.6 Data Source - IP Address .....	12
6.1.7 Coloring .....	12
6.1.8 Re-Order Screens .....	14
6.2 Alarm Screens .....	15
6.2.1 Alarm Conditional Configurations.....	15
6.3 Network .....	16
6.4 Modbus Server .....	17
6.5 Date / Time Settings.....	18
6.6 Relay Settings.....	18
6.7 User Settings .....	19
6.8 Administration .....	20
Appendix A: Drawings & Dimensions.....	21

---

## Introduction

Thank you for choosing Accutron Instruments for your monitoring needs. This manual will review the setup and operating procedures of your Accutron InfoScript display.

The Accutron InfoScript is a Modbus ready informational display that can be connected directly to your Modbus TCP network to instantly display important information where your workers need it. The 4-line display allows up to 35 characters per line and can directly output data from Modbus registers it can see. Alarm Screens can be programmed and configured to trigger when you want critical information to be instantly displayed.

If you have any suggestions on improvements of this product, please share it with us. We value your input. This product was designed to be user friendly, and we are actively looking on how we can improve our products to satisfy our customers.

---

## Section 1: General Information

### 1.1 Safety Guidelines

This device should only be set up and operated in conjunction with this manual. Qualified personnel are only authorized to install and operate this equipment in accordance with established safety practices and standards.

### 1.2 Information About Your Accutron InfoScript

When you first receive your Accutron InfoScript, ensure you record the following information shown below. If you need to contact Customer Service, this information will allow us to provide you more efficient service. This information is located on the label on the side of your InfoScript.

*Table 1: Accutron InfoScript Information*

Accutron InfoScript	
<b>Part Number:</b>	
<b>Serial Number:</b>	

## Section 2: Specifications

Connections:	<b>Large:</b> Screw terminal blocks <b>Mini:</b> RJ45 Network Jack Optional 12 pin M12 connector with cable and fly leads
Input Power:	<b>Large:</b> PoE compliant 48V 25.5W 802.3at (42.5–57.0 V) AC Input Terminals 110 to 240 VAC <b>Mini:</b> PoE compliant 48V 25.5W 802.3at (42.5–57.0 V) 24 VDC
Interfaces:	Ethernet (RJ45): Modbus TCP, HTML
User Outputs:	3 Dry Contact Relay outputs
Enclosure:	<b>Large:</b> Nema 4X, 316 Stainless Steel <b>Mini:</b> IP66 ABS Enclosure
Mounting:	<b>Large:</b> Top-mounted hanging rings ½" 13UNC threaded side ports Optional Tilting Side mounts <b>Mini:</b> Tilting Side bracket mounts
Programming:	Web Page
Default IP:	192.168.1.101
Temperature Range:	-40°C to + 80°C
Display:	1, 2 and 4 line RGB display 32 x 160 Pixels up to 35 characters per line

**Note:** Supported web browsers, Firefox v52+, Chrome v57+, Microsoft Edge v80+, Internet Explorer is not supported.



### Section 3: Communication and Power Wiring Diagram

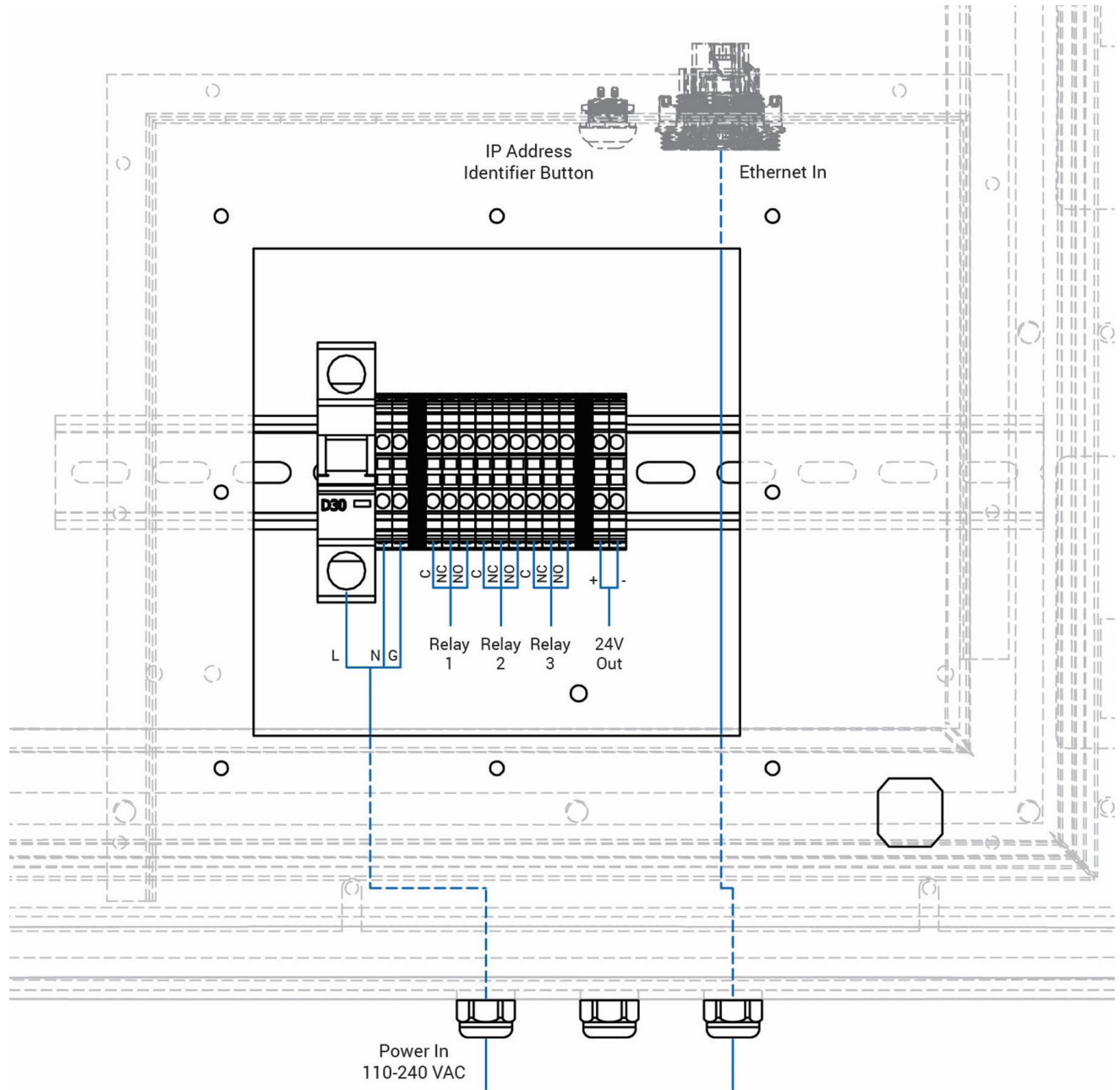

Figure 1: InfoScript Large Power Wiring Diagram

## Section 4: Device Overview

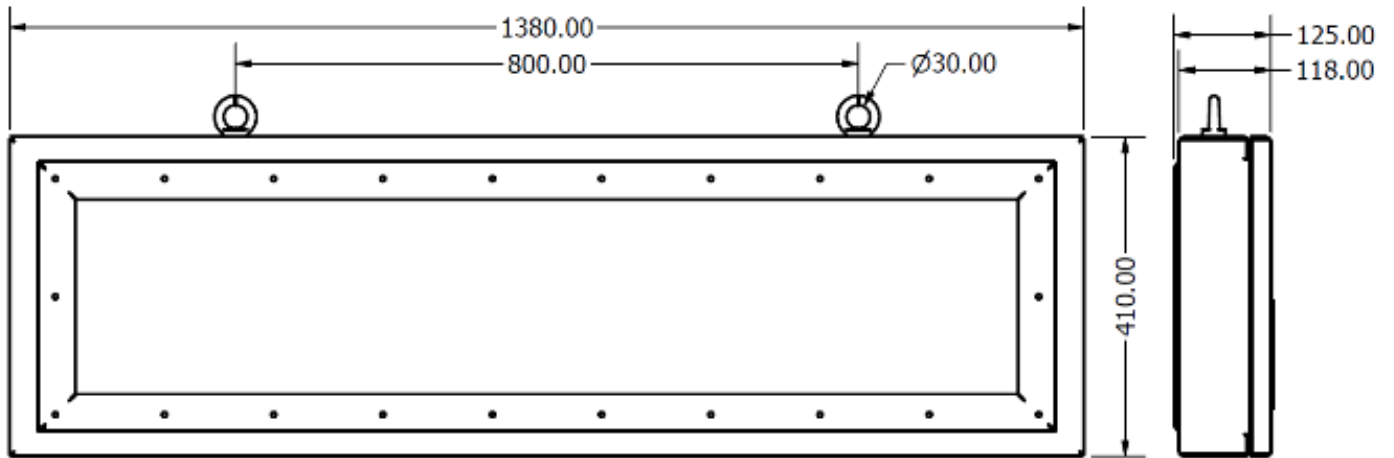

Figure 2: InfoScript Large Dimensions in mm

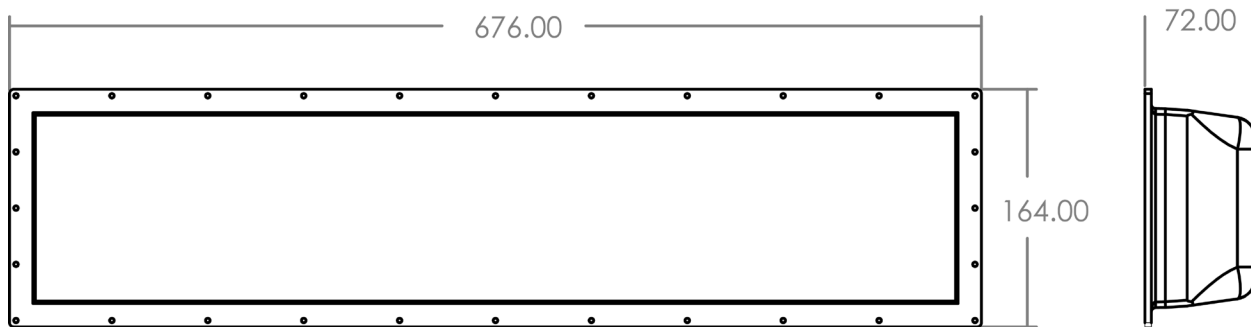

Figure 3: InfoScript Mini Dimensions in mm

## Section 5: Initial Setup

Connect your Accutron InfoScript to power and plug the device into your network.

When your InfoScript display boots, you should see various logo and informational screens including version information, support contact info, and current IP address. Providing there are no screens configured, a “Nothing configured” screen should be displayed with the current IP address.

The InfoScript’s default IP Address is 192.168.1.101/24. Ensure your computer’s network settings are properly configured to connect to the InfoScript.

## Section 6: Configuring Screens – The Web Interface

The Accutron InfoScript is accessed through a web browser. After properly configuring your computers network settings, enter your InfoScript’s IP address in your browser, and you will be brought to the Login Screen. The default password is ‘accutron’. There is currently no username support. Leave the username blank at this time.

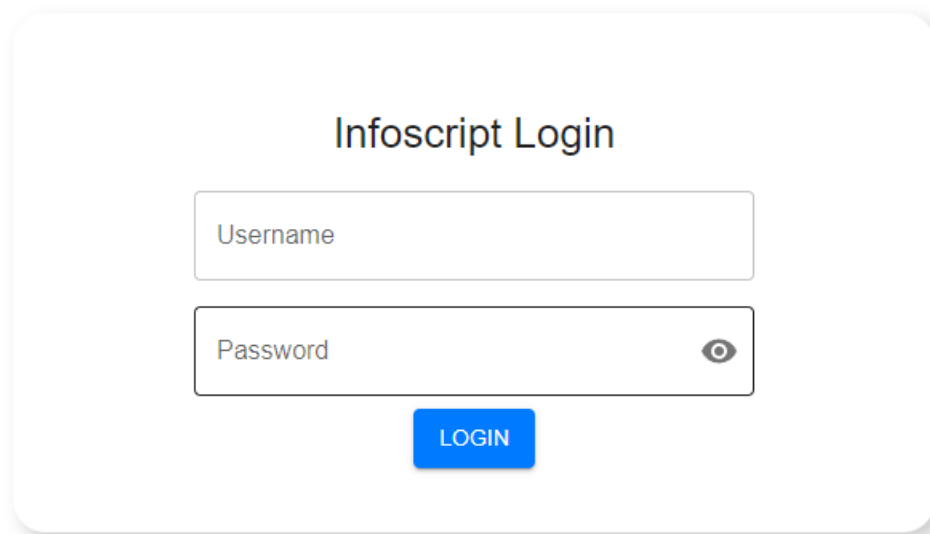

*Figure 4: InfoScript Web Interface Login Screen*

After successfully logging in, you will see the InfoScript **Screens** page. The left bar allows you to navigate the different configuration menus on the InfoScript. The area to the right displays the contents of the selected menu and allows you to configure your device.

## 6.1 Screens

The Screens menu allows you to configure various screens on your InfoScript. Click the “add screen” to add a new screen.

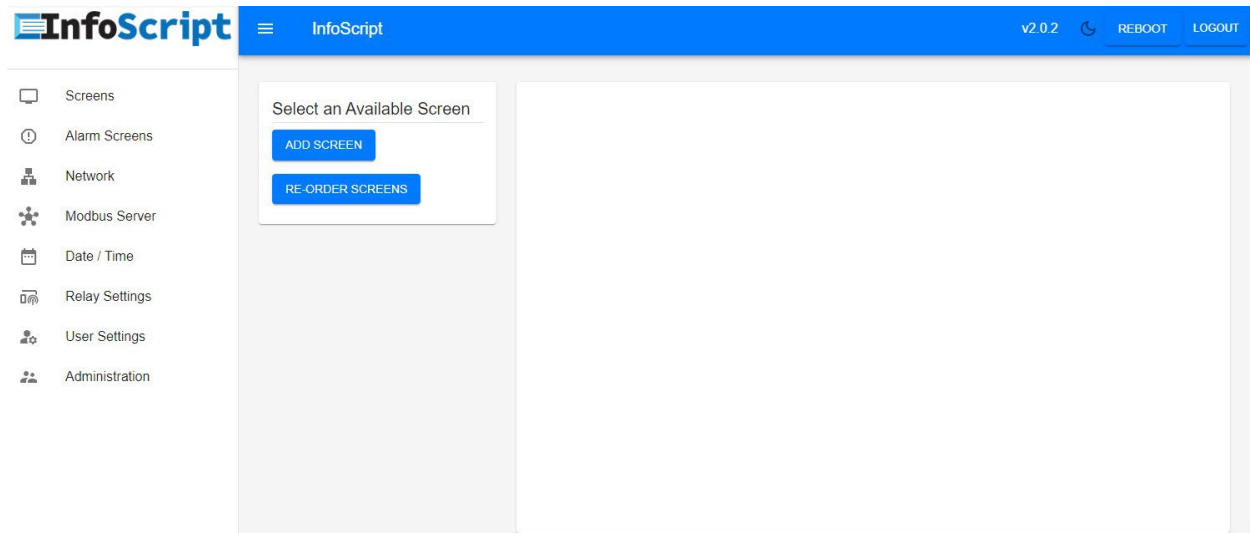

Figure 5: InfoScript Web Interface - Screens Page

### 6.1.1 General Screen Settings

At the top of the screen configuration menu, you will find your general screen settings.

- **Screen Name:** This field allows you to configure the name of your screen. This will be shown at the top of the screen configuration menu, as well as on your list of screens. This allows you to easily organize and identify which screen you are editing.
- **Duration:** This controls how long this screen will be displayed, before transitioning to the next screen. This field is in seconds.
- **Font Height:** This controls how many lines tall the font will be when writing text to the screen, with 4 lines being the largest font (Each letter will be 4 lines tall). Automatic allows the InfoScript to pick an appropriate font height based on how many lines of text you wish to display. If your font height is set to automatic and only one line is entered, then the InfoScript will set the font height to the maximum, which will limit the number of characters that can be written.
- **Alignment:** This controls the default alignment of text you enter to be displayed on your screen.
- **Screen Preview:** This displays a general preview of what the InfoScript will write to the screen. It is not a One-to-One preview of how each pixel will be displayed on the screen, but instead can be used as guide to see how much text will be written to the screen, and where it will be cut off.

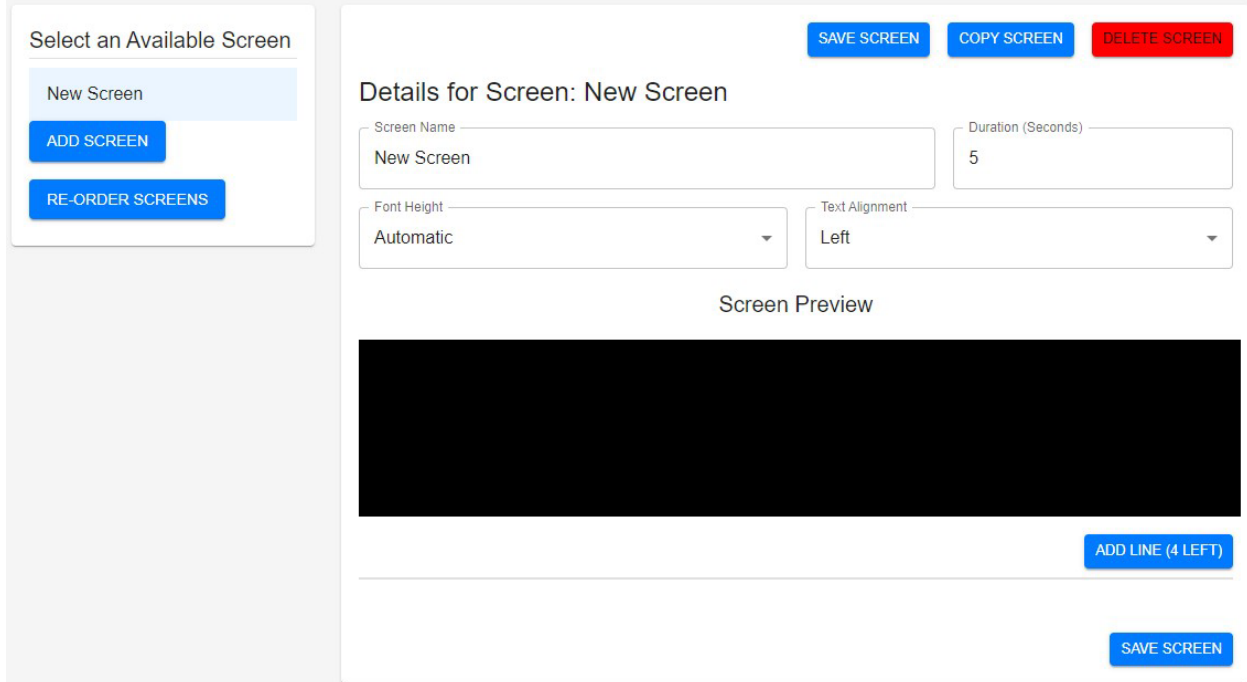

Figure 6: InfoScript Web Interface – Adding a New Screen

### 6.1.2 Line Settings

Click **ADD LINE (4 LEFT)** button to add a new line to the screen.

The Accutron InfoScript allows you to display up to 4 lines of text per screen. Each line can be configured the same way as shown. At the top left of the line settings section, you will see the line number that you are editing. At the top right side of this are two arrows. These allow you to easily move the line up or down to swap positions with other lines on that screen. The red **REMOVE LINE** button at the top right deletes the line from the screen. The **Data Source** drop down menu defines what type of line will be displayed. Depending on the type, the line settings may appear different.

### 6.1.3 Data Source - Text

This will display a static message as defined by the user. Text is entered in the **Left Side** and/or **Right Side** fields. The coloring can be selected on the **COLORING** tab. See section **6.1.7 Coloring** for more information.

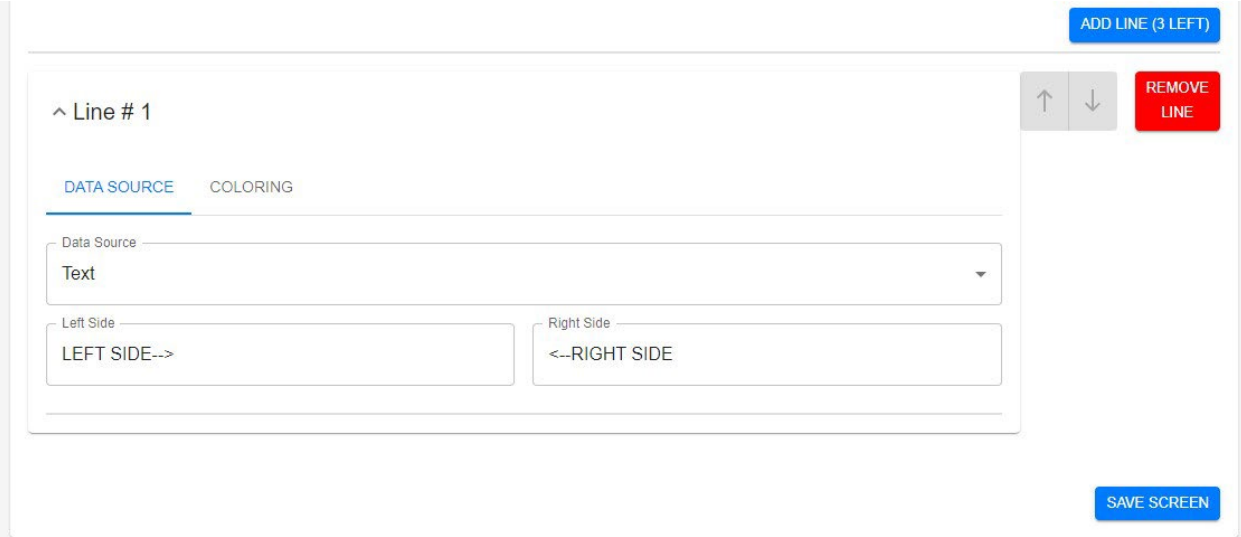

Figure 7: InfoScript Web Interface – Text Data Source

### 6.1.4 Data Source - Modbus Data

This allows you to display data from a Modbus register. The sign can act as both a Modbus Master and a Modbus Slave device. This can be configured per line and is controlled by the **Modbus Mode** setting.

#### Fetch as Modbus Client

If the **Modbus Mode** is set to **Fetch as Modbus Client**, the sign will pull from another Modbus device connected via Modbus TCP network.

- IP Address / Hostname: This defines the IP Address of the Modbus device you are trying to read.
  - Port: This is the Port information for the Modbus device you are trying to read. (usually 502).
  - Slave ID: This tells the sign the Slave ID of the device you are trying to read.
  - Register: This will be the register of the Modbus device that will be displayed on the sign.
- Prefix/Suffix: When you configure the Modbus information of the value you wish to display, it will automatically be shown on the InfoScript. You can then add text before/after the number, using Prefix/Suffix boxes. In this example, the degrees symbol is entered via ALT codes. ALT + 0176 on the numbered keypad.

^ Line # 1

↑ ↓
REMOVE LINE

DATA SOURCE
COLORING
FORMATTING
RANGE MAPPING

Data Source  
Modbus Data

Modbus Mode  
Fetch as Modbus Client

Modbus Data Type  
INT16

IP Address / Hostname  
192.168.1.101

Port  
502

Server ID  
1

Register Address  
40000

Prefix  
TEMPERATURE:

Suffix  
°C

Figure 8: InfoScript Web Interface –Modbus Data Source

### Receive as Modbus Server

If the **Modbus Mode** is set to **Receive as Modbus Server**, the sign will act as a Modbus slave device, and display information from its internal registers. These would need to be written to by other means, such as from a PLC.

- Register Address: Defines the internal register that will be displayed by the sign.
- Prefix/Suffix: The InfoScript will automatically display the value at the register defined above. If you wish to add text before/after the number, you may do so by adding it to the Prefix/Suffix boxes.

## Modbus Data Type options

### 16-bit UInt/ 16-bit Int:

This allows you to display an unsigned (UInt) or a signed (int) 16-bit integer from a Modbus register.

### 32-bit UInt/ 32-bit Int:

This allows you to display an unsigned (UInt) or a signed (int) 32-bit integer from a Modbus register. This is similar to setting up a 16-bit Int, with the addition of configuring the value's Endianness. This can either be **Little-Endian** or **Big-Endian**. Refer to the manual of the device you are reading to determine this.

### 32-bit Float:

This allows you to display a 32-bit float from a Modbus register. This is similar to setting up a 32-bit Int, however instead of defining Endianness, the **Byte Format** can be configured. Refer to the manual of the device you are reading to determine this.

### Coil:

This allows you to display a 1-bit value from a Modbus register. This will display an **ON** or **OFF** message.

### String:

This allows you to define a range of Modbus registers to be read and displayed as text. You define the starting address in the Register Address box, and you can specify the length of Modbus registers to be read in the String Length box.

## Coloring Tab

See section **6.1.7 Coloring** for more information on settings.

## Formatting Tab

The **Formatting** tab allows you to further modify how your Modbus values will be displayed.

- Decimal Precision: This controls how many decimals will be displayed for the Modbus value.
- Scaling Factor: This will multiply the Modbus value directly by the **scaling factor** value before it is displayed on the sign. The new scaled value will be displayed on the InfoScript.

## Range Mapping Tab

Range mapping allows you to define upper and lower bounds of your register value and remap this to a scaled range to display on the InfoScript. For example, if you have a temperature measurement device which outputs temperature over a range of values from 4000 to 20000, you may wish to remap these to more readable values on the InfoScript. If 4000 represents the instrument's lowest temperature range of -50 C, and 20000 represents the instrument's highest detection range of 50 C, this can be mapped to the sign as such:



^ Line # 1

DATA SOURCE   COLORING   FORMATTING   RANGE MAPPING

---

Source Range	Lower Bound 4000	Upper Bound 20000
Destination Range	Lower Bound -50	Upper Bound 50

Figure 9: InfoScript Web Interface –Modbus Settings Range Mapping

The **Source Range** will define the range of values that will be output by the device being read, and the **Destination Range** will define the range of values that will be displayed on the InfoScript. If the InfoScript received values outside of the specified source range, it will display a message of either less than the lower limit or greater than the higher limit. With the above example, if a value of 2500 is sent to the InfoScript from the temperature instrument, the temperature will be displayed as:

TEMPERATURE: < -50 °C

Note: If a scaling factor is being used with the range mapping, the scaling factor will be applied first, and then the scaled value will be mapped to the specified range. It is recommended to leave the Scaling factor set to 1 if range mapping will be used.

### 6.1.5 Data Source - Date/Time Display

This allows you to display the current date and time as stored by the InfoScript (The date and time settings are configurable on the Date/Time webpage).

- Day-of-week Format: Allows you to change between none, short (Abbreviated to first 3 letters) or full (displays the full week name)
- Date Format: Choose how the date is displayed (i.e. dd/mm/yyyy, mm/dd/yy, etc)
- Time Format: Chose how the time will be displayed (none, 12-hour, or 24-hour).

### 6.1.6 Data Source - IP Address

This allows you to display the current IP Address of the InfoScript. This is typically only used for default screens when first configuring the device.

### 6.1.7 Coloring

The **Coloring** tab allows you to define the color of the line displayed on your InfoScript. You can specify the Prefix Color, Value Color, and Suffix Color. The Value Color is what ever data you have defined from Data source (i.e. Modbus values, date/time, etc.). The Prefix and Suffix colors will change the

color of any text configured to display before or after the data. Color values can be entered as a hex value, or you can select a color from your list of predefined colors. The Infoscript ships with default colors set up, but these can be changed in your user settings.

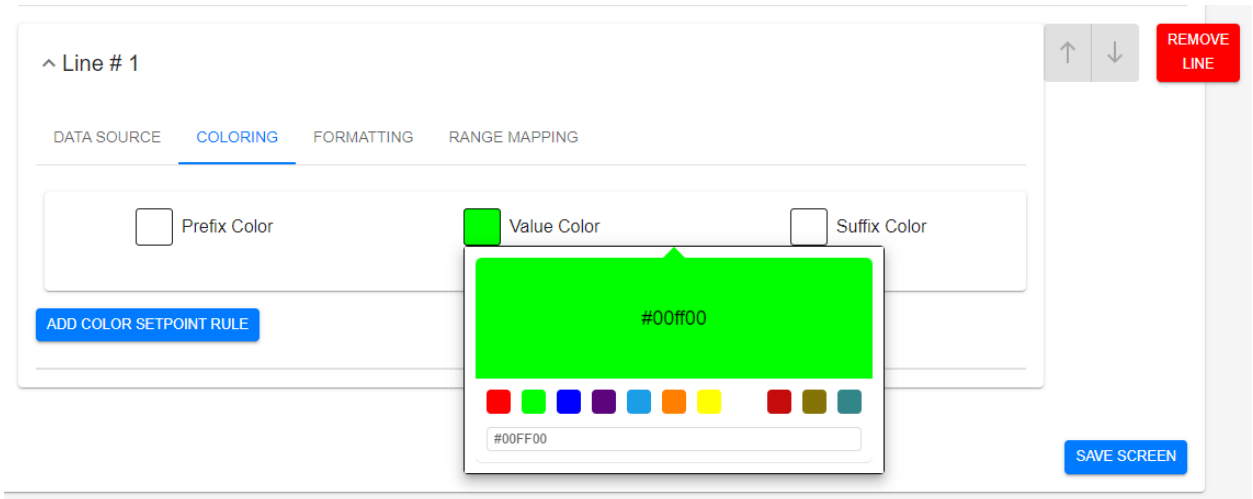

Figure 10: InfoScript Web Interface – Coloring Settings

### Color Setpoint Rules

You can add set points to change the color of data being displayed based on its value. For example, if you have a range of values from 0 to 100, you can display any number below 50 in green, and then have the value be displayed as red once it is over 50. You can define any number of setpoint rules.

To define a rule, click on the blue Add Color Setpoint Rule button. A new line will be added on the webpage where you can define the value and direction of when the setpoint is active. You can set the operator to be Less Than, Greater Than, or Equal to, and then input the Data Value number that you want the setpoint to trigger at.

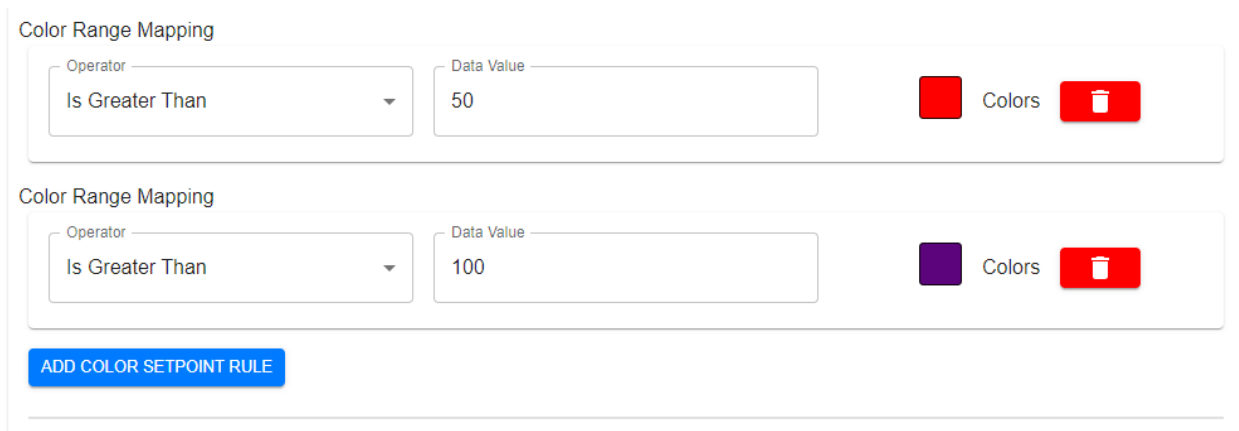
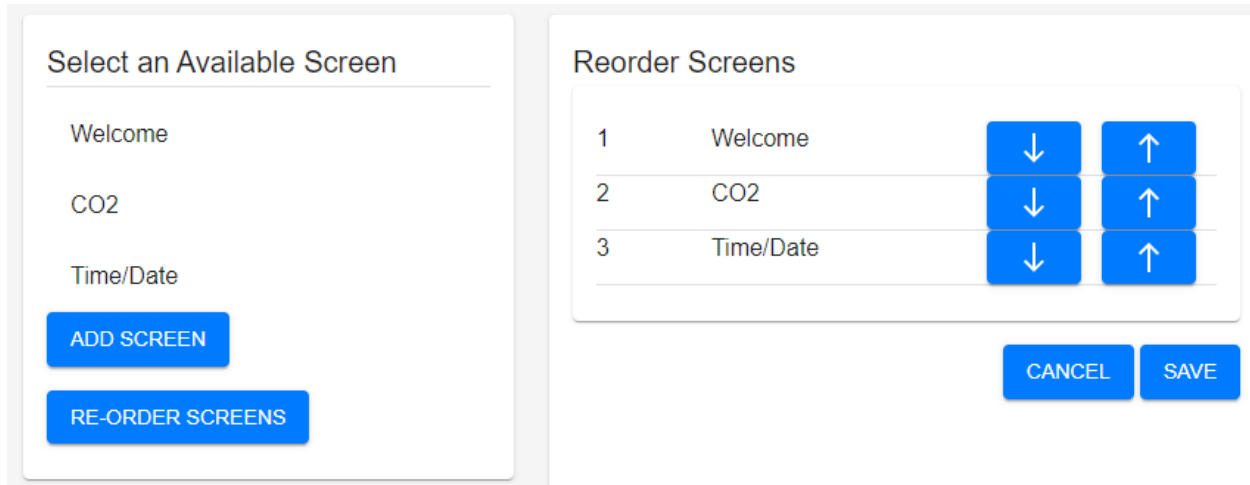

Figure 11: InfoScript Web Interface –Add Color Setpoint Rule

### 6.1.8 Re-Order Screens

This menu allows you to change the order in which your screens will be displayed. The InfoScript will scroll through each of your screens in the order defined in this menu. Screens can be easily re-arranged by moving them up or down in the queue using the up and down arrows on the right. To apply the new order, click the blue **Save** button. See section **6.1.7 Coloring** for information on colouring settings.



The screenshot shows two panels. The left panel, titled "Select an Available Screen", lists three screens: "Welcome", "CO2", and "Time/Date". Below the list are two blue buttons: "ADD SCREEN" and "RE-ORDER SCREENS". The right panel, titled "Reorder Screens", displays a table with three rows. Each row contains a screen number, the screen name, and two blue buttons with white arrows (down and up). The first row is "1 Welcome", the second is "2 CO2", and the third is "3 Time/Date". Below the table are two blue buttons: "CANCEL" and "SAVE".

Order	Screen Name	Down Arrow	Up Arrow
1	Welcome	↓	↑
2	CO2	↓	↑
3	Time/Date	↓	↑

Figure 12: InfoScript Web Interface – Re-Order Screens Settings

## 6.2 Alarm Screens

**Alarm screens** allow you to display messages on your InfoScript if user-defined conditions are met. This can be useful for defining warning conditions for workers, displaying brief announcement messages at set times of the day, etc. For example, you may wish to display an alert message to workers if temperature levels become too high for safe working environments, by defining an alarm screen that only displays when a value greater than 40 is detected on a Modbus register that is outputting temperature.

### 6.2.1 Alarm Conditional Configurations

The **Alarm Settings** menu will appear similar to the Basic Screens menu, and the screens themselves will be defined in a similar manner. The key difference will be the conditional configuration.

#### Alarm Settings

This screen will display when the following variable...

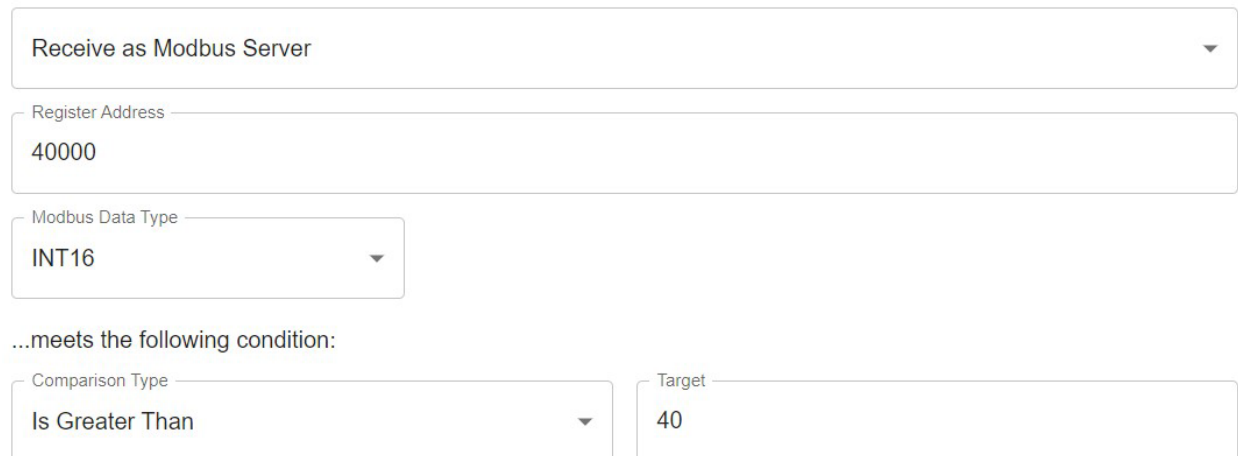

Receive as Modbus Server

Register Address  
40000

Modbus Data Type  
INT16

...meets the following condition:

Comparison Type  
Is Greater Than

Target  
40

And the following relays will be triggered:



Relay 1       Relay 2       Relay 3

Figure 13: InfoScript Web Interface – Alarm Settings

The conditional configuration is used to set the parameters that will trigger the **Alarm Screen**. The menu is broken up into two sections:

#### The screen will display when the following variable...

This section defines the Modbus variable that you wish to use to determine when your conditional screen will be displayed. Like other Modbus variables, this can be read from another device (Fetch as Modbus Master) or this can be read from the InfoScript's internal registers (Receive as Modbus Slave). The Register location settings and value type will be defined in this section.

---

...meets the following condition:

This section defines the criteria to compare the Modbus value to, in order to determine if the conditional slide shall be displayed or not.

- Comparison Type: This may be set to **Is Equal to**, **Is Less than**, or **Is Greater than**. This will determine how the Modbus value will be compared to the **Target** value when determining whether to display the **Alarm Screen** or not.
- Target Value: This is the value that the defined Modbus value will be compared with.

And the following relays will be triggered:

This will allow you to configure which, if any, relays will be toggled when the alarm screen condition is met.

Note: If a relay is selected for use here, it will be unavailable for use through the Relay Settings page. If a relay output has been set up on the Relay Settings page, it will also be unavailable to be used for an Alarm Screen. If that is the case, the toggle button for that relay will not be displayed.

When the comparison is met, and while it remains met, the Alarm Screen will be displayed. While the Alarm Screen is being displayed, it will supersede the basic screens, and only the conditional slide will be displayed. Once the condition is no longer met, the basic screens will be displayed and continue to cycle through their queue as normal.

Multiple Alarm Screens can be met, and they do not require the same condition to be true. If multiple Alarm Screens are active, or if multiple Alarm Screens are defined to trigger on the same condition, then the InfoScript will cycle through the Alarm Screens, displaying them for the length of time as defined during their configuration. Only Alarm Screens whose conditions are met will be displayed. If multiple Alarm Screens are configured and some of the defined conditions are not met, these screens will not be displayed. Once all conditional triggers are no longer met, then the InfoScript will return to displaying the basic screens.

## 6.3 Network

The Network page allows you to configure your device's IP address and network settings. To access this page initially, you must connect directly to the display using an ethernet cable. The display's default IP address is 192.168.1.101 and will be displayed on the bootup screen. Once you configure your network settings, you must click the **Save** button at the bottom, then **Apply Settings**. The new network settings should be applied without restarting. Restart the device if in doubt. This can be done by removing the power from the device and then plugging it back in. If the new settings have not been applied and the old settings are still in place, you should be able to reboot button at the top of the webpage.

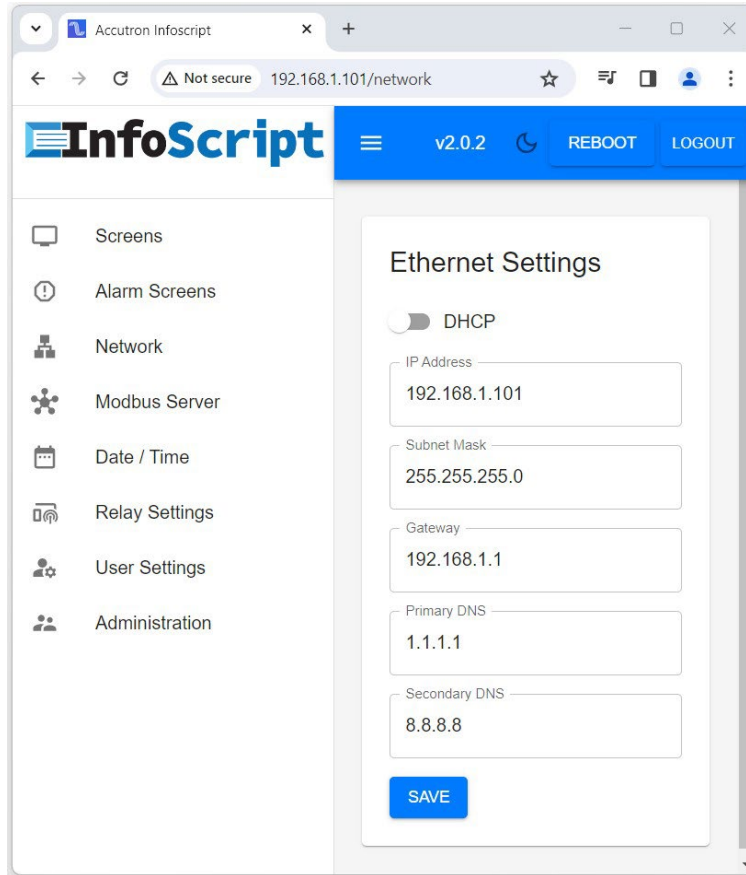

Figure 14: InfoScript Web Interface – Network Settings Tab

## 6.4 Modbus Server

The Modbus Server page allows you to configure the Modbus settings of the InfoScript. This allows you to define the port and slave ID of the device. You must click the blue **Save** button in order for any changes to apply.

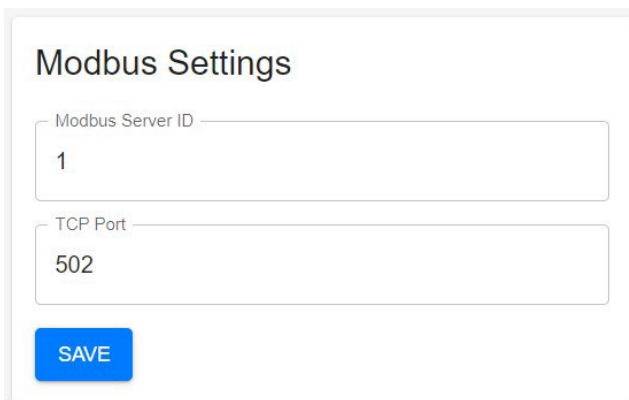
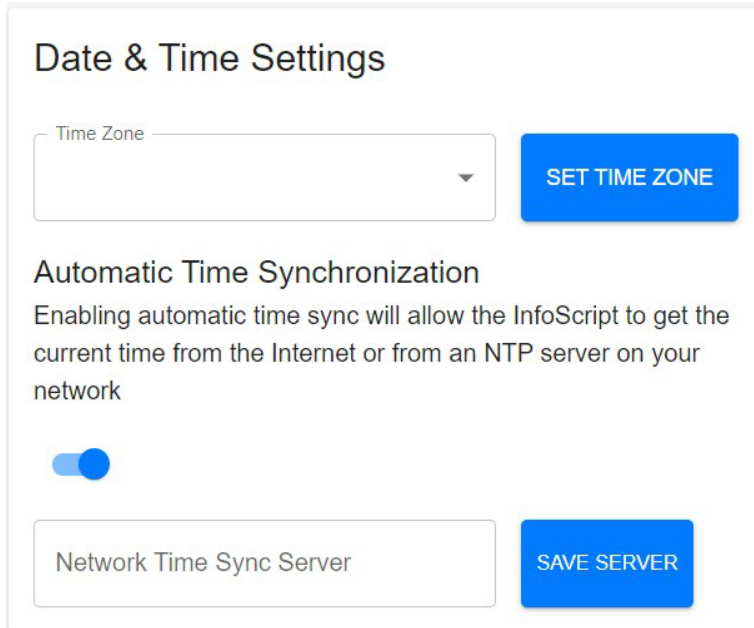

Figure 15: InfoScript Web Interface – Modbus Settings Tab

## 6.5 Date / Time Settings

The Date and Time settings page allows you to configure your **Time Zone** and **Network Time Sync Server** (NTP). If your network doesn't have an NTP server, toggle the **Automatic Time Synchronization** button and you can set the time manually.



**Date & Time Settings**

Time Zone

**Automatic Time Synchronization**  
Enabling automatic time sync will allow the InfoScript to get the current time from the Internet or from an NTP server on your network

Network Time Sync Server

Figure 16: InfoScript Web Interface – Date and Time Settings Tab

## 6.6 Relay Settings

The Infoscript has 3 relay outputs which can be configured in two ways. The first way, as described in the Alarm Screens section, would be to tie the relay output to a specific alarm screen that the Infoscript is displaying.

However, the relay outputs can also be defined independently, so that your standard configured messages do not need to be interrupted for a relay to toggle. This is done in the Relay Settings tab. A relay condition can be configured by clicking the Add Condition button. The configuration is the same as in the Alarm Screen. You can define how the modbus data will be accessed (As a client or server), the modbus address and data type, the comparison type (above, below, etc.), and then the target value. Relays configured through this page will toggle when the conditions are met, but the data displayed on the Infoscript will not change.

**Relay: 1** REMOVE

Conditional Toggle

This relay will toggle when the following variable...

Receive as Modbus Server ▼

Register Address

040001

Modbus Data Type

UINT16 ▼

...meets the following condition:

Comparison Type

Is Equal To ▼

Target

1

SAVE

**Relay: 2** ADD CONDITION

*Figure 17: InfoScript Web Interface – Relay Conditional Toggle Settings*

**Note:** When you configure a relay in the Relay Settings page, it will be unavailable for use through the Alarm Screens page. If a relay is being used on an Alarm Screen, then it will also be unavailable to be used through the Relay Settings page.

Relay: 2

⚠ This Relay is currently configured in an alarm screen!

*Figure 18: InfoScript Web Interface – Relay Warning When Used on an Alarm Screen*

## 6.7 User Settings

**Username** – The InfoScript current doesn’t support usernames. Change password support only.

**Change Password** – To change the password of the InfoScript, enter the current password in the specified field, the new password in the specified field, then click **Change Password**. If the password is accepted, the change will be applied. If there is an error with the current password, the password will not be changed. The password is case sensitive.

**Custom Colors** – You can choose from the 8 pre-configured colors, or further customize your colors anywhere across the full color spectrum.



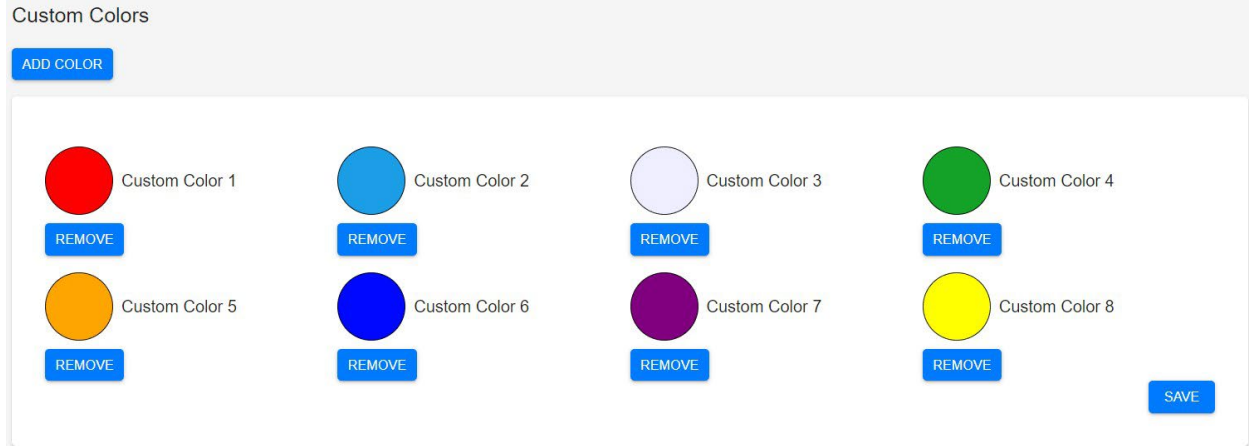

Figure 19: InfoScript Web Interface – Custom Colour Settings

## 6.8 Administration

The Administration page allows you to **Export Settings** to download a file for later recovery, **Import Settings** to upload a previously saved settings file, **Delete All Screens** to wipe all screens and display the default screen, or **Factory Reset** to reset all settings.

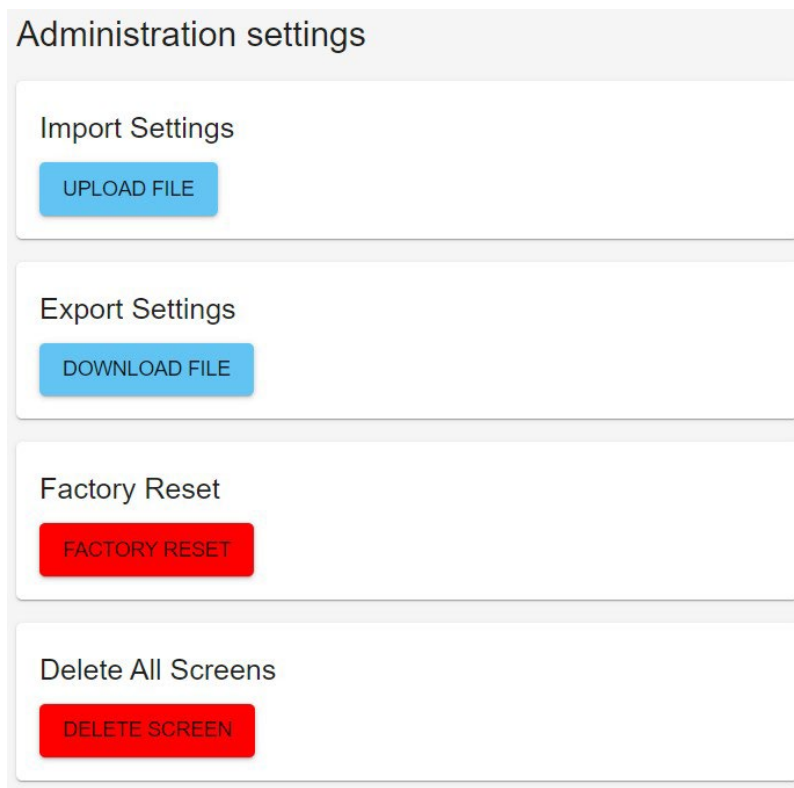

Figure 20: InfoScript Web Interface – Administration Settings

## Appendix A: Drawings & Dimensions

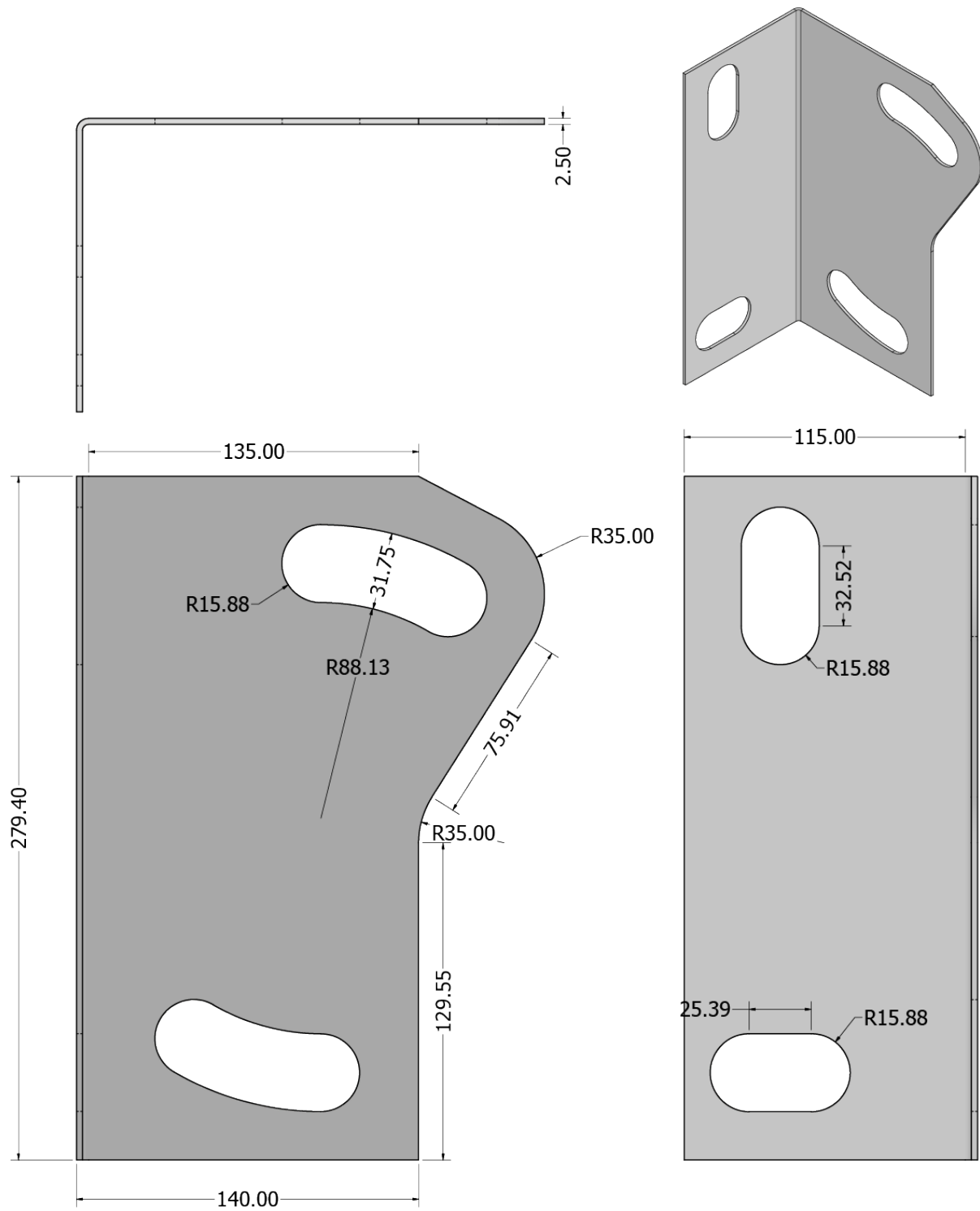

Figure 21: InfoScript Large Mounting Brackets

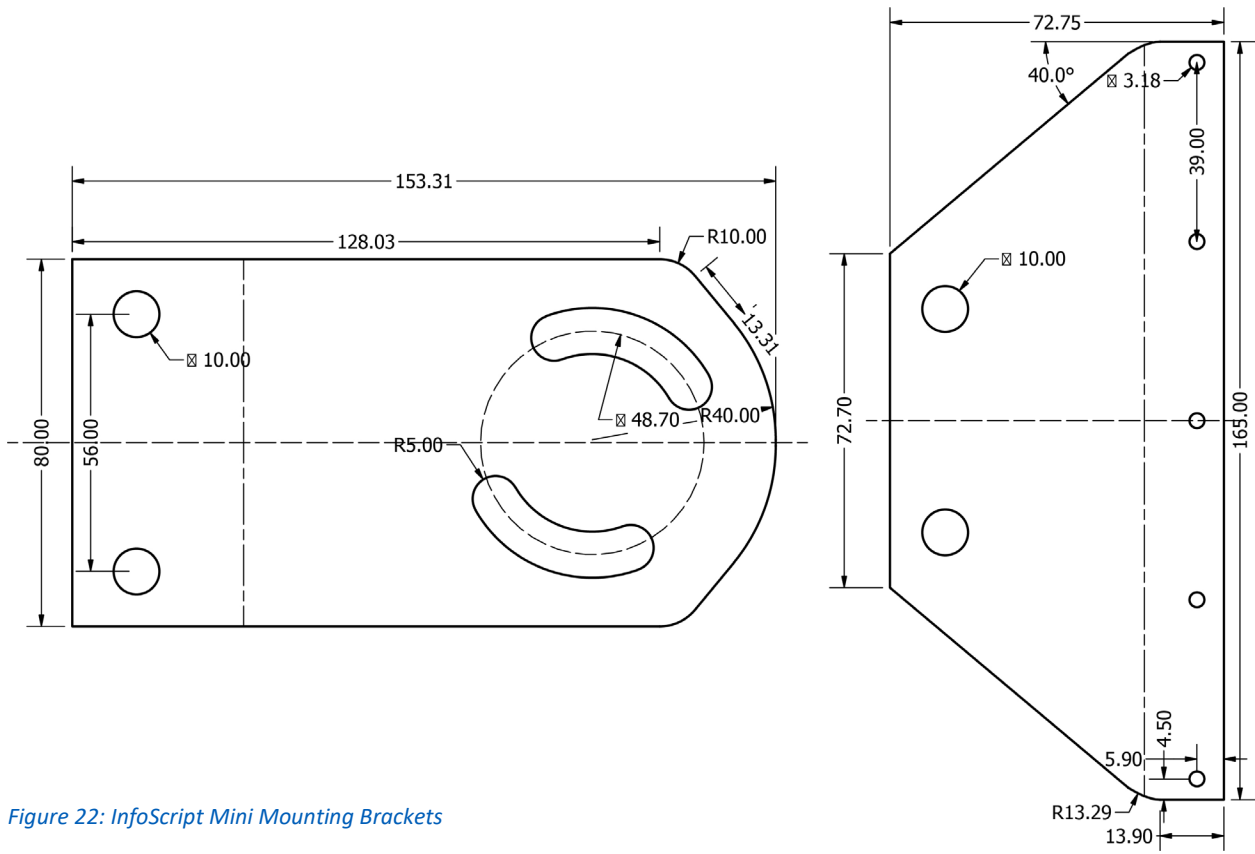

Figure 22: InfoScript Mini Mounting Brackets

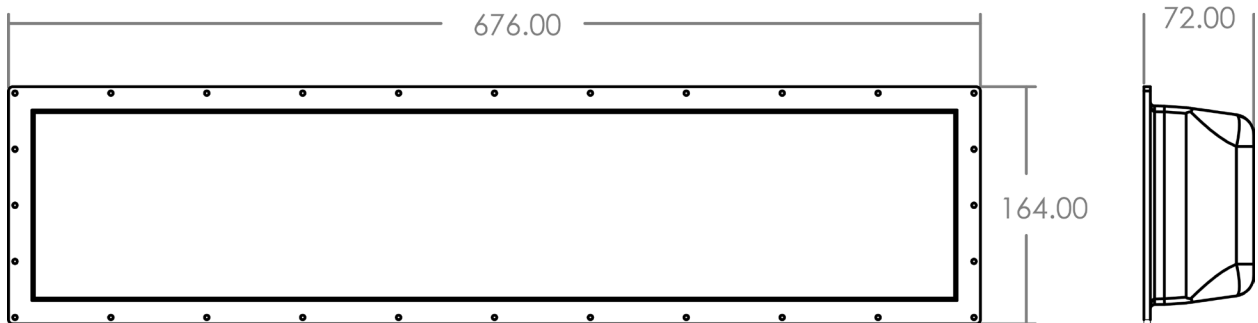
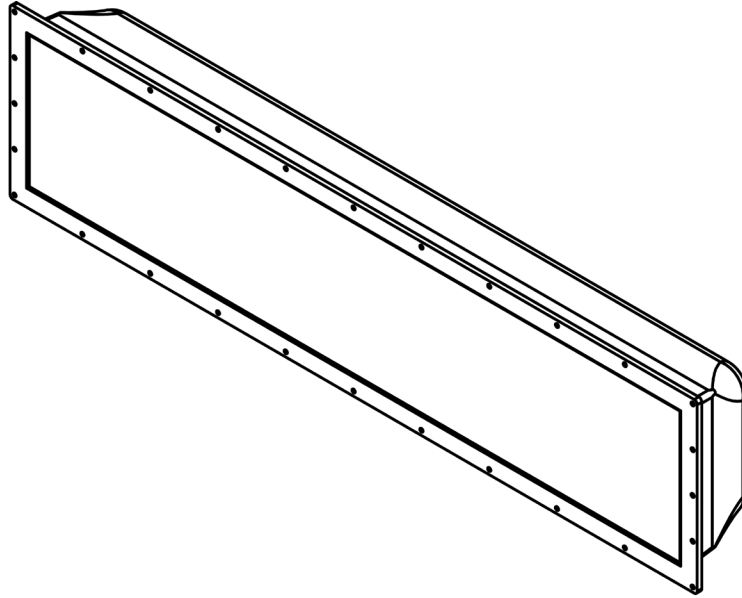

Figure 23: InfoScript Mini

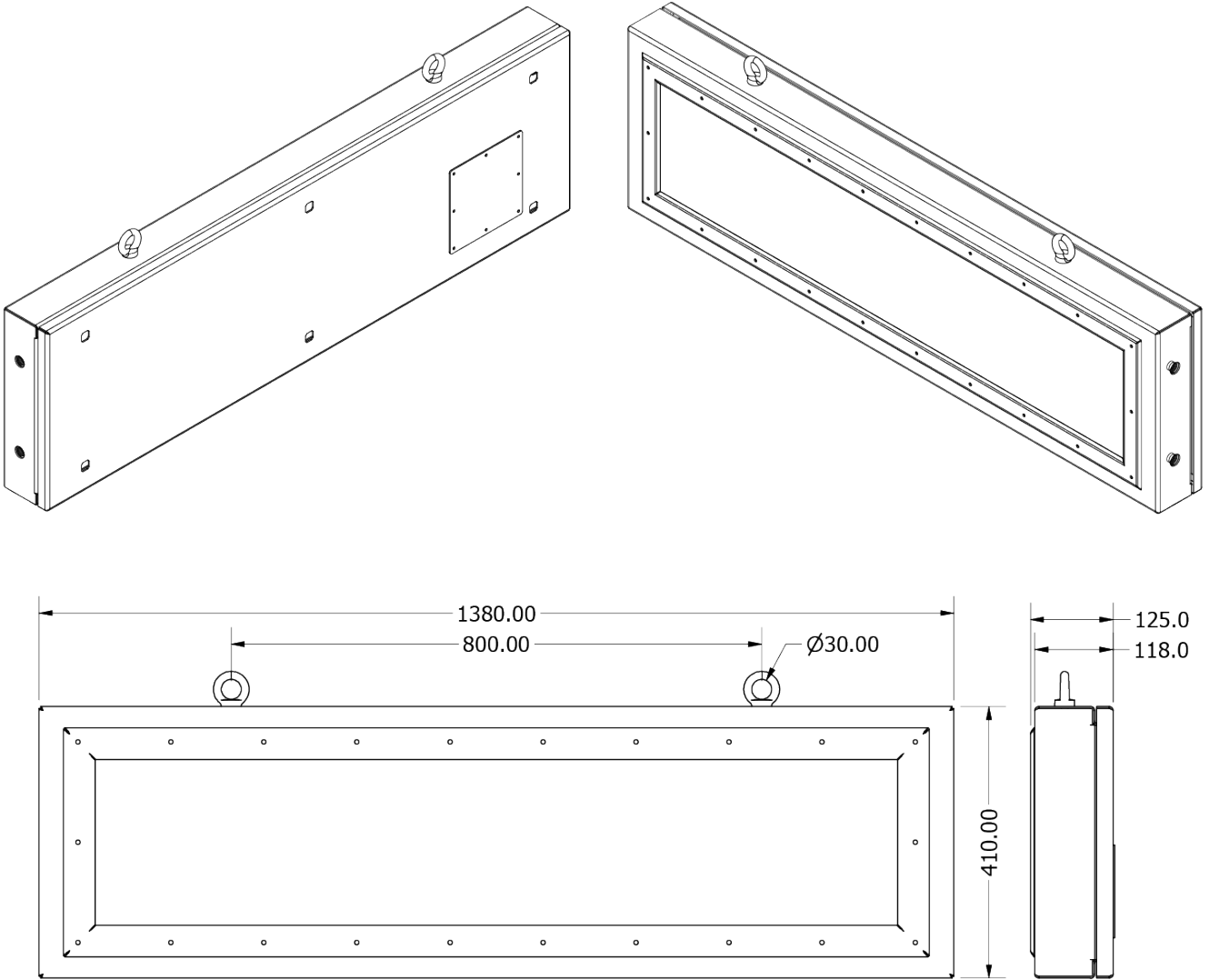
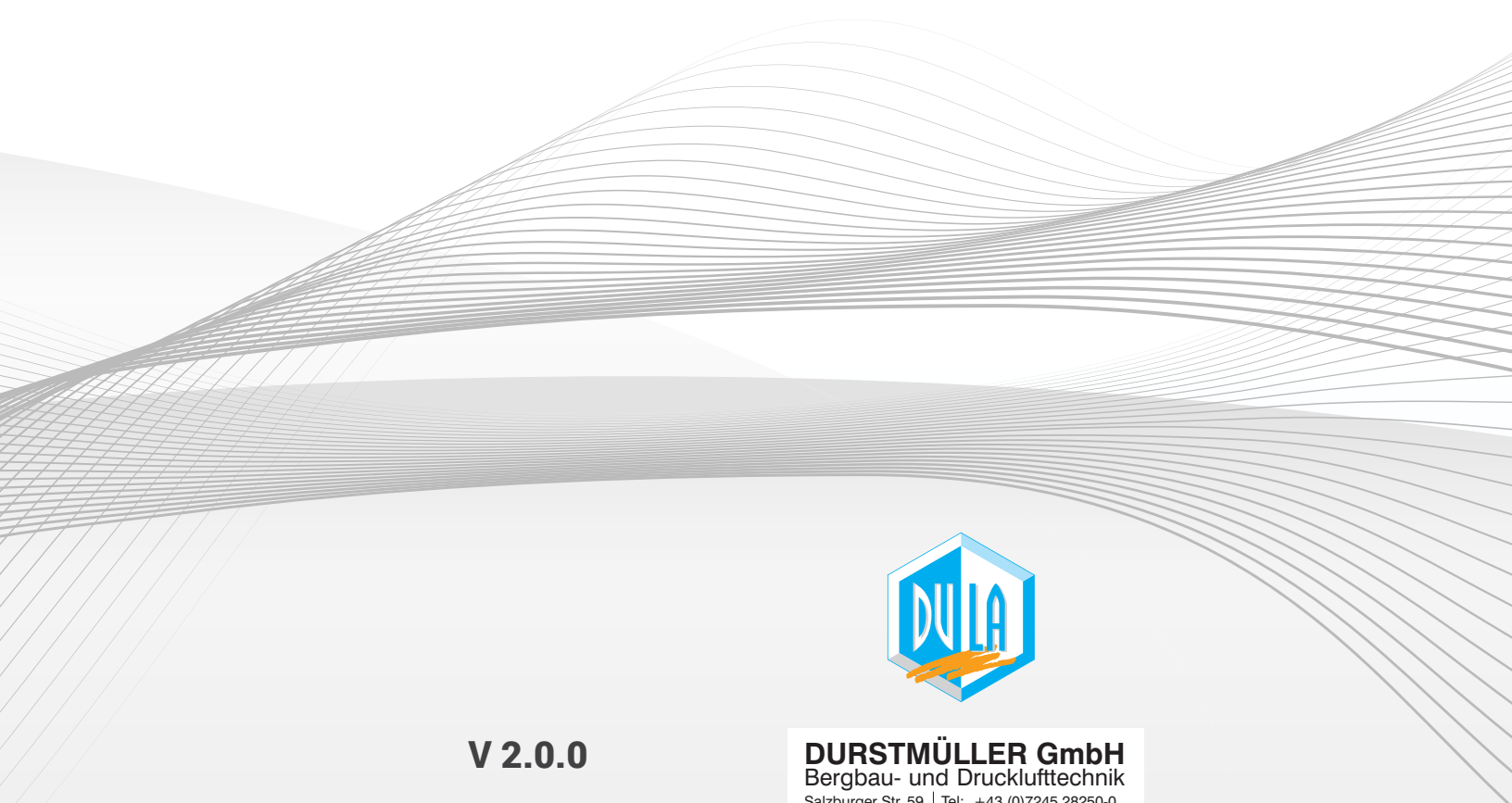

Figure 24: InfoScript Large



**V 2.0.0**

For InfoScript  
Large & Mini Versions

**DURSTMÜLLER GmbH**  
Bergbau- und Drucklufttechnik  
Salzburger Str. 59 | Tel: +43 (0)7245 28250-0  
4650 Lambach | Fax: +43 (0)7245 28250-50  
Austria | e-mail: office@dula.at  
web: www.dula.at